

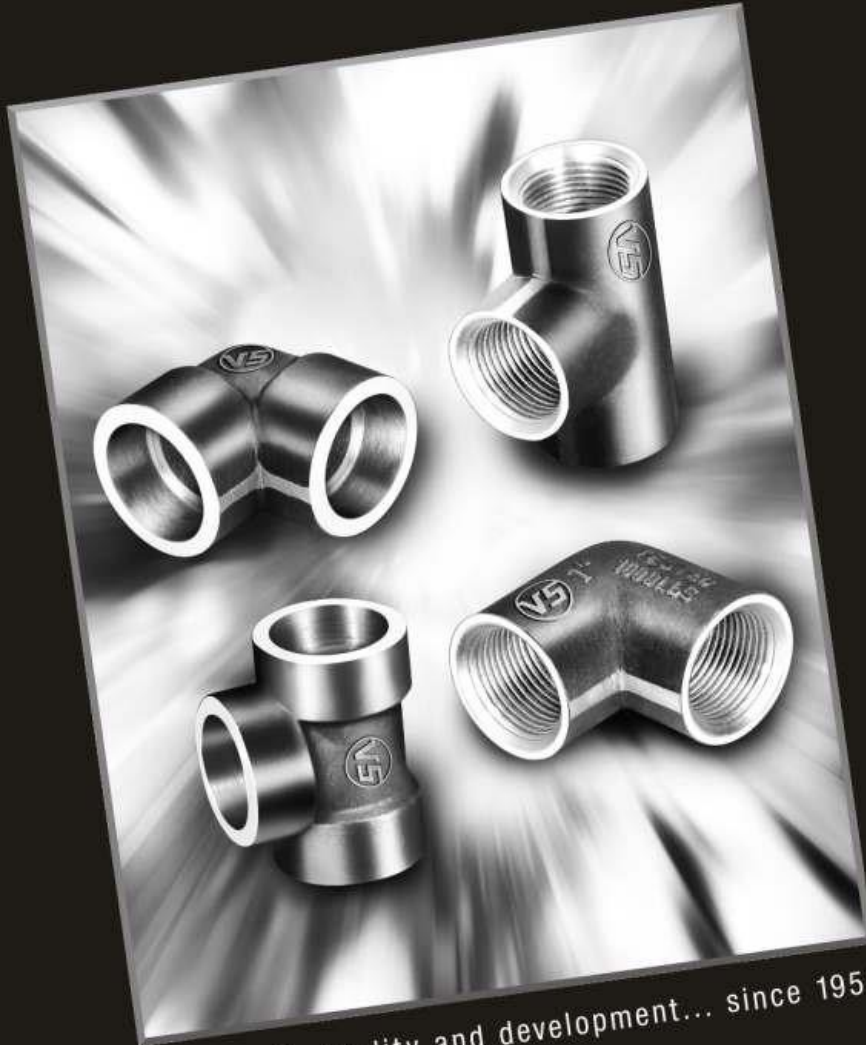

THE NO. 1
FORGED STEEL
PIPE FITTINGS



harmony in quality and development... since 1950



Technical Aspects

We take great pride in manufacturing Forged Steel Pipe Fittings in accordance with recommended Standard Specifications.

- (1) **ASME B.16.11-2011 / IS 4712:2011** for Forged Steel High Pressure Pipe Fittings with Socket Welding & Threaded End Connections. We use the finest Quality of steel Suitable for Forged Steel High Pressure Socket Welding & Threaded Fittings.

The End Connection of these fittings are thoroughly Checked using Calibrated **Plug Gauges, Thread Plug Gauges** and are leak Tested at **2000 PSIG hyd., 3000 PSIG hyd., 6000 PSIG hyd.** Threaded fitting is available in - **NPT, BSPT & BSP Threaded End Connections.**

Socket Weld Fittings are checked using plug Gauges and leak tested at 3000 PSIG hyd., 6000 PSIG hyd., 9000 PSIG hyd.

- (2) **MATERIAL SPECIFICATION:-**

- i. ASTM A-105, A-350 LF2, A-106 (Carbon Steel)
- ii. ASTM A-182 (F-304, F-304L, F-316, F-316L, F-304H, F-316H, F-317L, F-321, F-11, F-22, F-91) (Stainless Steel & Low Alloy Steel)

- (3) **FINISHING:-**

- i. Carbon Steel - Galvanized or Black.
- ii. Low Alloy Steel - Black
- iii. Stainless Steel - Pickled

- (4) **IS:1239 (Part 2) 2011 / BS EN 10241 - 2000** For Forged Steel Pipe Fittings with Threaded End Connections.

We use the finest quality of steel specially ment for forged Steel Pipe Fittings, This Steel has minimum Tensile Strength of 320N/mm². The Threads of these fittings comply with requirements of IS-554:1985.

We also manufacture fittings with **NPT** Thread Connections. These Fittings are Thoroughly Checked with Calibrated Thread Gauges and are Leak tested at **1000 PSIG hyd.**

'VS' Brand of Forged Steel Pipe Fittings are Synonymous to Quality & Endurance. The Brand has no Complaints for Leakage on Fitment or in Operation when fitted on Fluid systems. Working within a Recommended Pressure Range.

All **'VS'** Fittings have a Black finish and these are Pre-Treated to prevent Rust formation Prior to packaging. These fittings can also be Hot Galvanized as per IS : 4736 - 1986

**Forged Steel
High Pressure Socket Weld
Pipe Fittings 3000 Lbs.**



THE NO. 1 FORGED
STEEL PIPE FITTINGS





Socket Weld Elbow 90°

THE NO.1 FORGED STEEL PIPE FITTINGS

▼ Art No. VS-3001

FORGED 3000 Lbs BLACK

Manufacturing 'VS' pipe fittings for big chemical and pharmaceutical industries asks for perfection. Our socket welding elbows live up to the required standards of perfection in quality and endurance.



a structure for Application - Reaction Tank

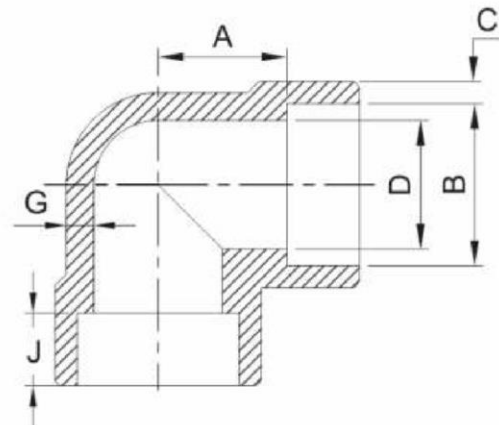

Class Designation : 3000 Lbs DIMENSIONS AS PER ASME B 16.11 - 2011 / IS : 4712 : 2011 (CLASS 20)

NOMINAL SIZE		SOCKET BORE DIA		BORE DIA OF FITTING		SOCKET WALL THICKNESS	MIN. DEPTH OF SOCKET	CENTER TO BOTTOM OF SOCKET		BODY WALL THICKNESS
		B		D		C	J	A		G
Inch	MM	Min.	Max.	Min.	Max.	Min.		Min.	Max.	Min.
1/8"	6	10.8	11.2	6.1	7.6	3.18	10.5	11	12	2.41
1/4"	8	14.2	14.6	8.5	10	3.78	10.5	11	12	3.02
3/8"	10	17.6	18	11.8	13.3	4.01	10.5	13.5	15	3.2
1/2"	15	21.8	22.2	15	16.6	4.67	10.5	15.5	17	3.73
3/4"	20	27.2	27.6	20.2	21.7	4.9	13.5	19	20.5	3.91
1"	25	33.9	34.3	25.9	27.4	5.69	13.5	22.5	24	4.55
1¼"	32	42.7	43.1	34.3	35.8	6.07	13.5	27	29	4.85
1½"	40	48.8	49.2	40.1	41.6	6.35	13.5	32	34	5.08
2"	50	61.2	61.7	51.7	53.3	6.93	17	38	40	5.54
2½"	65	73.9	74.4	61.2	64.2	8.76	18	42	43.5	7.01
3"	80	89.8	90.3	76.4	79.4	9.52	18	57	59.5	7.62

ALL DIMENSIONS IN MM

Reducing Socket Weld Elbow 90°



FORGED 3000 Lbs BLACK

Art No. VS-3002 ▼

THE NO.1 FORGED STEEL PIPE FITTINGS



The aviation asks for nothing less than perfection & we provide perfection in every piece branded 'VS'

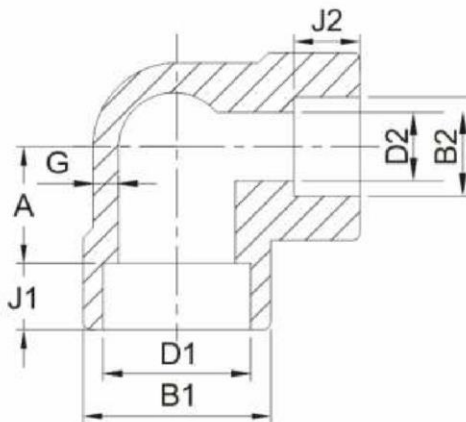

a structure for Application - Aviation Industry

Class Designation : 3000 Lbs

DIMENSIONS "VS" REDUCING SOCKET WELD ELBOW

NOMINAL SIZE		CENTRE TO BOTTOM OF SOCKET A		SOCKET BORE DIAMETER(B1)				SOCKET WALL THICKNESS C	BORE DIAMETER OF FITTING				BODY WALL THICKNESS G	DEPTH OF SOCKET	
Inch	MM	Min.	Max.	(B1) Min.	(B1) Max.	(B2) Min.	(B2) Max.		(D1) Min.	(D1) Max.	(D2) Min.	(D2) Max.		(J1) Min.	(J2) Min.
1/4"x1/8"	8x6	10	12	14.2	14.6	10.8	11.2	3.78	8.5	10	6.1	7.6	3.02	6.1	10.5
3/8"x1/4"	10x8	12	15	17.6	18	14.2	14.6	4.01	11.8	13.3	8.5	10	3.2	8.5	10.5
1/2"x3/8"	15x10	14	17	21.8	22	17.6	18	4.67	15	16.6	11.8	13.3	3.73	11.8	10.5
3/4"x1/2"	20x15	18	21	27.2	27.6	21.8	22.2	4.9	20.2	21.7	15	16.6	3.91	15	10.5
1"x1/2"	25x15	20	24	33.9	34.3	21.8	22.2	5.69	25.9	27.4	15	16.6	4.55	15	10.5
1"x3/4"	25x20	20	24	33.9	34.3	27.2	27.6	5.69	25.9	27.4	20.2	21.7	4.55	20.2	13.5
1 1/4"x3/4"	32x20	25	29	42.7	43.1	27.2	27.6	6.07	34.3	35.8	20.2	21.7	4.85	20.2	13.5
1 1/4"x1"	32x25	25	29	42.7	43.1	33.9	34.3	6.07	34.3	35.8	25.9	27.4	4.85	25.9	13.5
1 1/2"x1"	40x25	30	34	48.8	49.2	33.9	34.3	6.35	40.1	41.6	25.9	27.4	5.08	25.9	13.5
1 1/2"x1 1/4"	40x32	30	34	48.8	49.2	42.7	43.1	6.35	40.1	41.6	34.3	35.8	5.08	34.3	13.5
2"x1 1/4"	50x32	35	40	61.2	61.7	42.7	43.1	6.93	51.7	53.3	34.3	35.8	5.54	34.3	13.5
2"x1 1/2"	50x40	36	40	61.2	61.7	48.8	49.2	6.93	51.7	53.3	40.1	41.6	5.54	40.1	13.5
2 1/2"x2"	65x40	38.5	43.5	73.2	74.4	61.2	61.7	8.76	61.2	64.2	51.7	53.3	7.01	51.7	16
2 1/2"x1 1/2"	65x40	38.5	43.5	73.2	74.4	48.8	49.2	8.76	61.2	64.2	40.1	41.6	7.01	40.1	13.5
3"x2 1/2"	80x65	54.5	59.5	89.8	90.3	73.9	74.4	9.52	76.4	79.4	61.2	64.2	7.62	61.2	16
3"x2"	80x50	54.5	59.5	89.8	90.3	61.2	61.7	9.52	76.4	79.4	51.7	53.3	7.62	51.7	16

ALL DIMENSIONS IN MM



Socket Weld Tee

THE NO.1 FORGED STEEL PIPE FITTINGS

▼ Art No. VS-3003

FORGED 3000 Lbs BLACK

These 'VS' fittings are used in steam run applications like steam turbines and boilers because of their strength to curtail high pressures.



a structure for Application - Steam Turbine

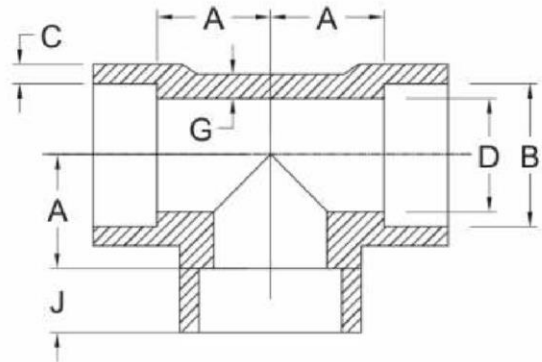

Class Designation : 3000 Lbs DIMENSIONS AS PER ASME B 16.11 - 2011 / IS : 4712 : 2011 (CLASS 20)

NOMINAL SIZE		SOCKET BORE DIA		BORE DIA OF FITTING		SOCKET WALL THICKNESS	MIN. DEPTH OF SOCKET	CENTER TO BOTTOM OF SOCKET		BODY WALL THICKNESS
		B		D		C	J	A		G
Inch	MM	Min.	Max.	Min.	Max.	Min.		Min.	Max.	Min.
1/8"	6	10.8	11.2	6.1	7.6	3.18	10.5	11	12	2.41
1/4"	8	14.2	14.6	8.5	10	3.78	10.5	11	12	3.02
3/8"	10	17.6	18	11.8	13.3	4.01	10.5	13.5	15	3.2
1/2"	15	21.8	22.2	15	16.6	4.67	10.5	15.5	17	3.73
3/4"	20	27.2	27.6	20.2	21.7	4.9	13.5	19	20.5	3.91
1"	25	33.9	34.3	25.9	27.4	5.69	13.5	22.5	24	4.55
1 1/4"	32	42.7	43.1	34.3	35.8	6.07	13.5	27	29	4.85
1 1/2"	40	48.8	49.2	40.1	41.6	6.35	13.5	32	34	5.08
2"	50	61.2	61.7	51.7	53.3	6.93	17	38	40	5.54
2 1/2"	65	73.9	74.4	61.2	64.2	8.76	18	42	43.5	7.01
3"	80	89.8	90.3	76.4	79.4	9.52	18	57	59.5	7.62

ALL DIMENSIONS IN MM

Reducing Socket Weld Tee



FORGED 3000 Lbs BLACK

Art No. VS-3004 ▼

THE NO.1 FORGED STEEL PIPE FITTINGS



These 'VS' fittings are synonymous to precision & they prove it in every field of application.

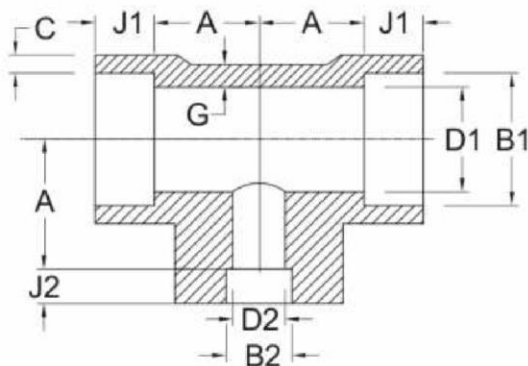

a structure for Application - Ash Handling Plant

Class Designation : 3000 Lbs DIMENSIONS "VS" REDUCING SOCKET WELD TEE

NOMINAL SIZE		CENTRE TO BOTTOM OF SOCKET A		SOCKET BORE DIAMETER(B1)				SOCKET WALL THICKNESS C	BORE DIAMETER OF FITTING				BODY WALL THICKNESS G	DEPTH OF SOCKET	
Inch	MM	Min.	Max.	(B1)		(B2)			(D1)		(D2)			(J1)	(J2)
1/4"x1/8"	8x6	10	12	14.2	14.6	10.8	11.2	3.78	8.5	10	6.1	7.6	3.02	10.5	10.5
3/8"x1/4"	10x8	12	15	17.6	18	14.2	14.6	4.01	11.8	13.3	8.5	10	3.2	10.5	10.5
1/2"x3/8"	15x10	14	17	21.8	22	17.6	18	4.67	15	16.6	11.8	13.3	3.73	10.5	10.5
3/4"x1/2"	20x15	18	21	27.2	27.6	21.8	22.2	4.9	20.2	21.7	15	16.6	3.91	13.5	10.5
1"x1/2"	25x15	20	24	33.9	34.3	21.8	22.2	5.69	25.9	27.4	15	16.6	4.55	13.5	10.5
1"x3/4"	25x20	20	24	33.9	34.3	27.2	27.6	5.69	25.9	27.4	20.2	21.7	4.55	13.5	13.5
1 1/4"x3/4"	32x20	25	29	42.7	43.1	27.2	27.6	6.07	34.3	35.8	20.2	21.7	4.85	13.5	13.5
1 1/4"x1"	32x25	25	29	42.7	43.1	33.9	34.3	6.07	34.3	35.8	25.9	27.4	4.85	13.5	13.5
1 1/2"x1"	40x25	30	34	48.8	49.2	33.9	34.3	6.35	40.1	41.6	25.9	27.4	5.08	13.5	13.5
1 1/2"x1 1/4"	40x32	30	34	48.8	49.2	42.7	43.1	6.35	40.1	41.6	34.3	35.8	5.08	13.5	13.5
2"x1 1/4"	50x32	35	40	61.2	61.7	42.7	43.1	6.93	51.7	53.3	34.3	35.8	5.54	16	13.5
2"x1 1/2"	50x40	36	40	61.2	61.7	48.8	49.2	6.93	51.7	53.3	40.1	41.6	5.54	16	13.5
2 1/2"x2"	65x40	38.5	43.5	73.2	74.4	61.2	61.7	8.76	61.2	64.2	51.7	53.3	7.01	16	16
2 1/2"x1 1/2"	65x40	38.5	43.5	73.2	74.4	48.8	49.2	8.76	61.2	64.2	40.1	41.6	7.01	16	13.5
3"x2 1/2"	80x65	54.5	59.5	89.8	90.3	73.9	74.4	9.52	76.4	79.4	61.2	64.2	7.62	16	16
3"x2"	80x50	54.5	59.5	89.8	90.3	61.2	61.7	9.52	76.4	79.4	51.7	53.3	7.62	16	16

ALL DIMENSIONS IN MM



Socket Weld Socket

THE NO.1 FORGED STEEL PIPE FITTINGS

▼ Art No. VS-3005

FORGED 3000 Lbs BLACK

Rigidity is the key word for manufacturing 'VS' fittings for steam hammers. These set the standards of perfection in quality and endurance.



a structure for Application - Steam Hammers

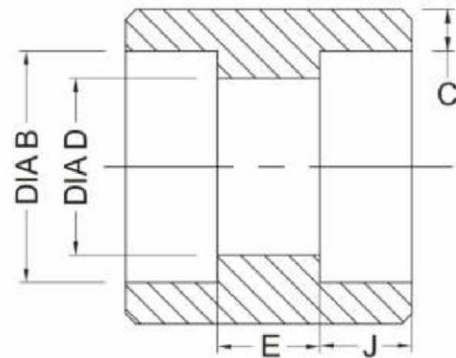

Class Designation : 3000 Lbs DIMENSIONS AS PER ASME B 16.11 - 2011 / IS : 4712 : 2011 (CLASS 20)

NOMINAL SIZE		SOCKET BORE DIA B		BORE DIA OF FITTING D		SOCKET WALL THICKNESS C	MIN. DEPTH OF SOCKET J	LAYING LENGTH E	
Inch	MM	Min.	Max.	Min.	Max.	Min.	Min.	Min.	Max.
1/8"	6	10.8	11.2	6.1	7.6	3.18	10.5	5	8
1/4"	8	14.2	14.6	8.5	10	3.78	10.5	5	8
3/8"	10	17.6	18	11.8	13.3	4.01	10.5	5	9
1/2"	15	21.8	22.2	15	16.6	4.67	10.5	6.5	12.5
3/4"	20	27.2	27.6	20.2	21.7	4.9	13.5	6.5	12.5
1"	25	33.9	34.3	25.9	27.4	5.69	13.5	8.5	16.5
1 1/4"	32	42.7	43.1	34.3	35.8	6.07	13.5	8.5	16.5
1 1/2"	40	48.8	49.2	40.1	41.6	6.35	13.5	8.5	16.5
2"	50	61.2	61.7	51.7	53.3	6.93	17	15	23
2 1/2"	65	73.9	74.4	61.2	64.2	8.76	18	15	23
3"	80	89.8	90.3	76.4	79.4	9.52	18	15	23

ALL DIMENSIONS IN MM

Reducing Socket Weld Socket/Coupling



FORGED 3000 Lbs BLACK

Art No. VS-3006 ▼

THE NO.1 FORGED STEEL PIPE FITTINGS



Manufacturing 'VS' pipe fittings for big industries units asks for perfection. Our fittings live up to those standards.

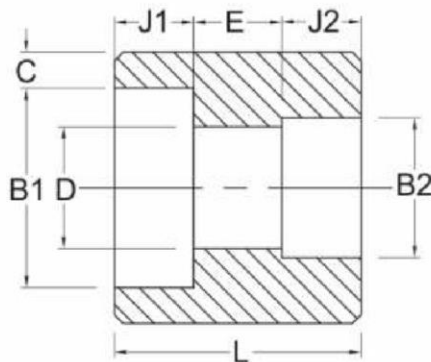

a structure for Application - Desalination Plant

Class Designation : 3000 Lbs DIMENSIONS "VS" REDUCING SOCKET WELD SOCKET/COUPLING

NOMINAL SIZE		SOCKET BORE DIAMETER(B1)				SOCKET WALL THICKNESS C	BORE DIAMETER OF FITTING		DEPTH OF SOCKET		DEPTH OF SOCKET	
		(B1)		(B2)			D		(J1)	(J2)	E	
Inch	MM	Min.	Max.	Min.	Max.	Min.	Min.	Max.	Min.	Max.	Min.	Min.
1/4"x1/8"	8x6	14.2	14.6	10.8	11.2	3.78	6.1	7.6	10.5	10.5	5	8
3/8"x1/4"	10x8	17.6	18	14.2	14.6	4.01	8.5	10	10.5	10.5	5	9
1/2"x3/8"	15x10	21.8	22	17.6	18	4.67	11.8	13.3	10.5	10.5	6	13
3/4"x1/2"	20x15	27.2	27.6	21.8	22.2	4.9	15	16.6	13.5	10.5	6	13
1"x1/2"	25x15	33.9	34.3	21.8	22.2	5.69	15	16.6	13.5	10.5	9	17
1"x3/4"	25x20	33.9	34.3	27.2	27.6	5.69	20.2	21.7	13.5	13.5	9	17
1 1/4"x3/4"	32x20	42.7	43.1	27.2	27.6	6.07	20.2	21.7	13.5	13.5	9	17
1 1/4"x1"	32x25	42.7	43.1	33.9	34.3	6.07	25.9	27.4	13.5	13.5	9	17
1 1/2"x1"	40x25	48.8	49.2	33.9	34.3	6.35	25.9	27.4	13.5	13.5	9	17
1 1/2"x1 1/4"	40x32	48.8	49.2	42.7	43.1	6.35	34.3	35.8	13.5	13.5	9	17
2"x1 1/4"	50x32	61.2	61.7	42.7	43.1	6.93	34.3	35.8	16	13.5	15	23
2"x1 1/2"	50x40	61.2	61.7	48.8	49.2	6.93	40.1	41.6	16	13.5	15	23
2 1/2"x2"	65x40	73.2	74.4	61.2	61.7	8.76	51.7	53.3	16	16	15	23
2 1/2"x1 1/2"	65x40	73.2	74.4	48.8	49.2	8.76	40.1	41.6	16	13.5	15	23
3"x2 1/2"	80x65	89.8	90.3	73.9	74.4	9.52	61.2	64.2	16	16	15	23
3"x2"	80x50	89.8	90.3	61.2	61.7	9.52	51.7	53.3	16	16	15	23

ALL DIMENSIONS IN MM



Socket Weld Cross

THE NO.1 FORGED STEEL PIPE FITTINGS

FORGED 3000 Lbs BLACK

Art No. VS-3007

Ship building industries all over India rely on 'VS' fittings for pipe lines layout in ship building applications.



a structure for Application - Boilers

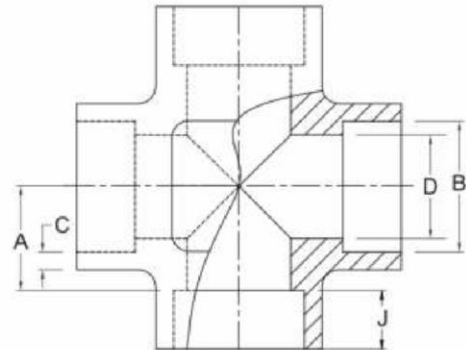

Class Designation : 3000 Lbs DIMENSIONS AS PER ASME B 16.11 - 2011 / IS : 4712 : 2011 (CLASS 20)

NOMINAL SIZE		SOCKET BORE DIA		BORE DIA OF FITTING		SOCKET WALL THICKNESS	Min. DEPTH OF SOCKET	CENTRE TO BOTTOM OF SOCKET		BODY WALL THICKNESS
		B		D		C	J	A		G
Inch	MM	Min.	Max.	Min.	Max.	Min.	Min.	Min.	Max.	Min.
1/8"	6	10.8	11.2	6.1	7.6	3.18	10.5	11	12	2.41
1/4"	8	14.2	14.6	8.5	10	3.78	10.5	11	12	3.02
3/8"	10	17.6	18	11.8	13.3	4.01	10.5	13.5	15	3.2
1/2"	15	21.8	22.2	15	16.6	4.67	10.5	15.5	17	3.73
3/4"	20	27.2	27.6	20.2	21.7	4.90	13.5	19	20.5	3.91
1"	25	33.9	34.3	25.9	27.4	5.69	13.5	22.5	24	4.55
1¼"	32	42.7	43.1	34.3	35.8	6.07	13.5	27	29	4.85
1½"	40	48.8	49.2	40.1	41.6	6.35	13.5	32	34	5.08
2"	50	61.2	61.7	51.7	53.3	6.93	17	38	40	5.54
2½"	65	73.9	74.4	61.2	64.2	8.76	18	42	43.5	7.01
3"	80	89.8	90.3	76.4	79.4	9.52	18	57	59.5	7.62

ALL DIMENSIONS IN MM



Socket Weld Elbow 45°

FORGED 3000 Lbs BLACK

Art No. VS-3008 ▼

THE NO.1 FORGED STEEL PIPE FITTINGS



'VS' fittings are being used in textile Industries also. Our socket weld elbow is a versatile component on almost every type of pipeline for plugging of fluid flow.

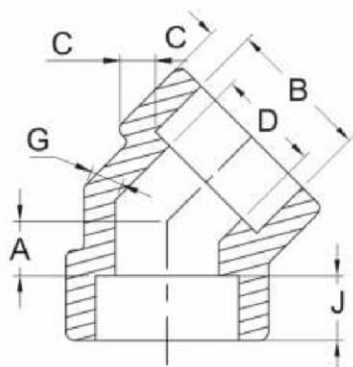

a structure for Application - Refineries

Class Designation : 3000 Lbs DIMENSIONS AS PER ASME B 16.11 - 2011 / IS : 4712 : 2011 (CLASS 20)

NOMINAL SIZE		SOCKET BORE DIA		BORE DIA OF FITTING		SOCKET WALL THICKNESS	MIN. DEPTH OF SOCKET	CENTER TO BOTTOM OF SOCKET		BODY WALL THICKNESS
		B		D		C	J	A		G
Inch	MM	Min.	Max.	Min.	Max.	Min.	Min.	Min.	Max.	Min.
1/8"	6	10.8	11.2	6.1	7.6	3.18	10.5	8.0	9.0	2.41
1/4"	8	14.2	14.6	8.5	10.0	3.78	10.5	8.0	9.0	3.02
3/8"	10	17.6	18.0	11.8	13.3	4.01	10.5	8.0	9.5	3.2
1/2"	15	21.8	22.2	15	16.6	4.67	10.5	11.0	12.5	3.73
3/4"	20	27.2	27.6	20.2	21.7	4.9	13.5	13.0	14.5	3.91
1"	25	33.9	34.3	25.9	27.4	5.69	13.5	14.0	16.0	4.55
1¼"	32	42.7	43.1	34.3	35.8	6.07	13.5	17.5	19.5	4.85
1½"	40	48.8	49.2	40.1	41.6	6.35	13.5	20.5	22.5	5.08
2"	50	61.2	61.7	51.7	53.3	6.93	17	25.5	27.5	5.54
2½"	65	73.9	74.4	61.2	64.2	8.76	18	28.5	31.0	7.01
3"	80	89.8	90.3	76.4	79.4	9.52	18	32.0	34.5	7.62

ALL DIMENSIONS IN MM



Socket Weld Union

THE NO.1 FORGED STEEL PIPE FITTINGS

▼ Art No. VS-3009

FORGED 3000 Lbs BLACK

'VS' fittings are being used in textile Industries also. Our socket weld union is a versatile component on almost every type of pipeline for plugging of fluid flow.



a structure for Application - Shipping

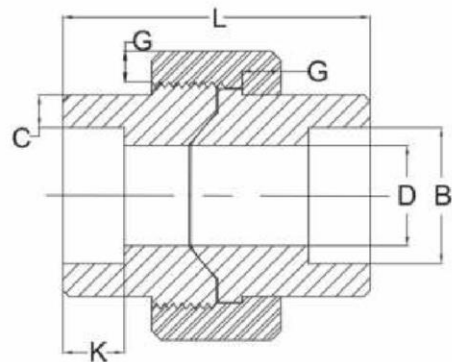

Class Designation : 3000 Lbs DIMENSIONS AS PER MSS-SP-83-2006

NOMINAL SIZE	SOCKET BORE DIA B		SOCKET WALL THICKNESS C	WATER WAY BORE D		NUT G	DEPTH OF SOCKET K	LENGTH ASSEM. L
	Min.	Max.		Min.	Max.			
1/4"	14.10	14.61	3.30	8.48	10.01	3.18	9.7	45
3/8"	17.53	18.03	3.51	11.76	13.28	3.43	9.7	50
1/2"	21.72	22.23	4.09	15.04	16.56	3.68	9.7	50
3/4"	27.05	27.56	4.27	20.17	21.69	4.06	12.7	60
1"	33.78	34.29	4.98	25.88	27.41	4.45	12.7	65
1 1/4"	42.55	43.05	5.28	34.29	35.81	5.21	12.7	75
1 1/2"	48.64	49.15	5.54	40.13	41.66	4.59	12.7	80
2"	61.11	61.62	6.05	51.74	63.26	6.35	15.7	90
2 1/2"	73.81	74.45	7.67	61.19	64.24	7.11	15.7	103

ALL DIMENSIONS IN MM

**Forged Steel
Pipe Fittings with
threaded end connection
1000 Lbs.**



THE NO.1 FORGED
STEEL PIPE FITTINGS





Elbow 90°

THE NO.1 FORGED STEEL PIPE FITTINGS

FORGED 1000 Lbs BLACK

▼ Art No. VS-1001

Manufacturing 'VS' pipe fittings for big refineries asks for perfection. Our fittings live up to the required standards of perfection in quality and endurance.



a structure for Application - Harbours

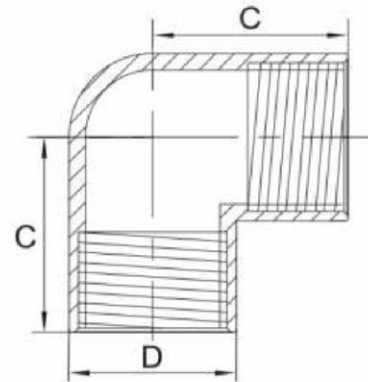

DIMENSIONS AS PER IS : 1239 (Part 2) 2011 / BS EN 10241 - 2000

NOMINAL SIZE OF OUTLET	MINIMUM LENGTH CENTER TO FACE	MINIMUM OUTER DIA
	C	D
6	16	15
8	22	18.5
10	24	22
15	32	27
20	35	32.5
25	43	39.5
32	51	49
40	52	56
50	64	68
65	76	84
80	89	98

ALL DIMENSIONS IN MM



Reducing Elbow 90°

FORGED 1000 Lbs BLACK

Art No. VS-1002 ▼

THE NO.1 FORGED STEEL PIPE FITTINGS

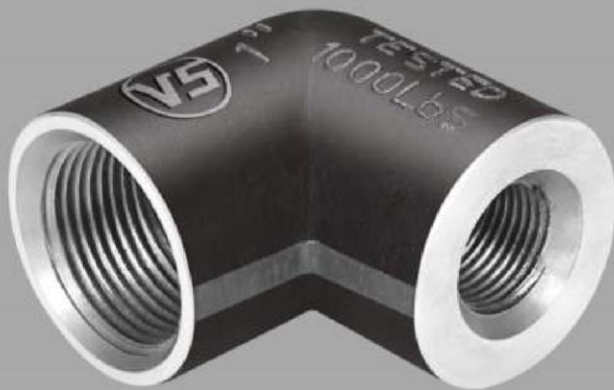

Manufacturing 'VS' pipe fittings for sugar mills asks for perfection. Our Reducing Elbow live up to the required standards of perfection from every angle.

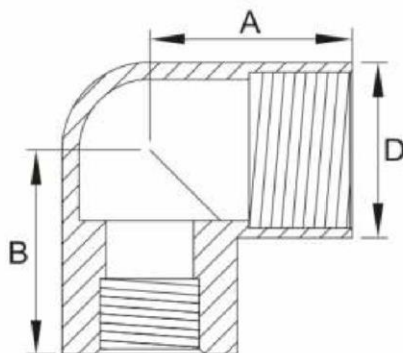

a structure for Application - Sugar Mills

DIMENSIONS AS PER IS : 1239 (Part 2) 2011 / BS EN 10241 - 2000

NOMINAL SIZE OF OUTLET	MIN. LENGTH OF CENTER TO FACE A	MIN. LENGTH OF CENTER TO FACE B	MINIMUM OUTER DIA D	NOMINAL SIZE OF OUTLET	MIN. LENGTH OF CENTER TO FACE A	MIN. LENGTH OF CENTER TO FACE B	MINIMUM OUTER DIA D
8x6	21	22	18.5	40x15	38	52	56
10x6	21	24	22	40x20	41	52	56
10x8	22	24	22	40x25	44	52	56
15x8	25	32	27	40x32	48	52	56
15x10	27	32	27	50x15	41	64	68
20x8	27	35	32.5	50x20	44	64	68
20x10	29	35	32.5	50x25	48	64	68
20x15	32	35	32.5	50x32	52	64	68
25x10	32	43	39.5	50x40	56	64	68
25x15	35	43	39.5	65x40	60	76	84
25x20	38	43	39.5	65x50	67	76	84
32x15	38	51	49	80x25	60	89	98
32x20	41	51	49	80x50	73	89	98
32x25	44	51	49				

ALL DIMENSIONS IN MM



Elbow 45°

THE NO.1 FORGED STEEL PIPE FITTINGS

▼ Art No. VS-1003

FORGED 1000 Lbs BLACK

Manufacturing these 'VS' pipe fittings for chemical applications like toxic gas handling is not like manufacturing any ordinary fitment. Fittings live upto those standards of rigidity and endurance perfectly.



a structure for Application - Gas Storage

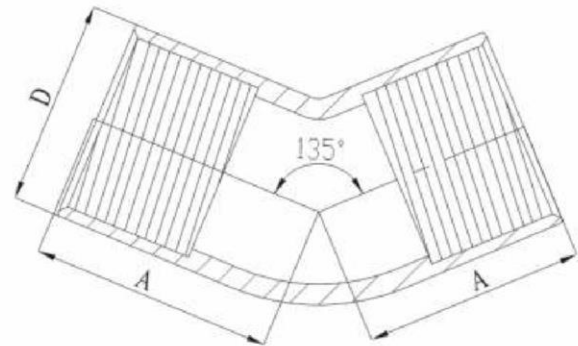

DIMENSIONS AS PER IS : 1239 (Part 2) 2011 / BS EN 10241 - 2000

NOMINAL SIZE OF OUTLET	MINIMUM LENGTH CENTER TO FACE	MINIMUM OUTER DIA
	A	D
6	16	15
8	17	18.5
10	19	22
15	22	27
20	27	32.5
25	33	39.5
32	38	49
40	44	56
50	51	68
65	60	84
80	73	98

ALL DIMENSIONS IN MM



Male / Female Elbow 90°

FORGED 1000 Lbs BLACK

Art No. VS-1004 ▼

THE NO.1 FORGED STEEL PIPE FITTINGS



Manufacturing 'VS' pipe fittings for sugar mills asks for perfection. Our Elbow Male/Female live up to the required standards of perfection from every angle.

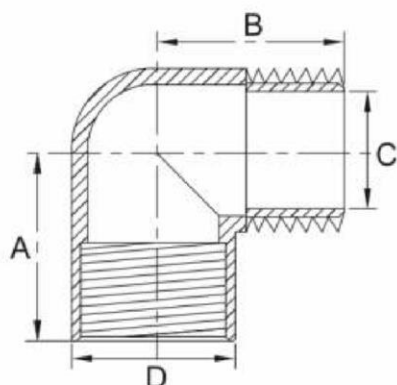

a structure for Application - Paper Mills

DIMENSIONS AS PER IS : 1239 (Part 2) 2011 / BS EN 10241 - 2000

NOMINAL SIZE OF OUTLET	MIN. LENGTH OF CENTER TO FACE A	MIN. LENGTH OF CENTER TO FACE B	BORE DIA OF MALE END C		MINIMUM OUTER DIA D
			Min.	Max.	
8	19	27	6.5	8	18.5
10	21	29	8.5	10.5	22
15	25	35	11.5	13	27
20	30	40	18	21	32.5
25	37	46	24	26	39.5
32	43	54	30	32	49
40	49	57	37	39	56
50	59	70	48	51	68
65	68	83	62	66	84
80	81	94	75	79	98

ALL DIMENSIONS IN MM



Tee

THE NO.1 FORGED STEEL PIPE FITTINGS

▼ Art No. VS-1005

FORGED 1000 Lbs BLACK

Forged steel 'VS' fittings for petrochemical industries require high quality, long life & total safety. Our fittings are made to fit these requirements.



a structure for Application - ONGC

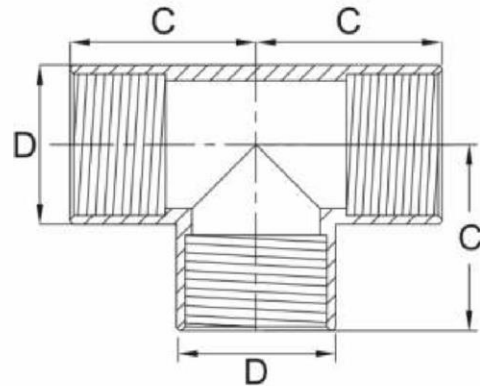

DIMENSIONS AS PER IS : 1239 (Part 2) 2011 / BS EN 10241 - 2000

NOMINAL SIZE OF OUTLET	MINIMUM LENGTH CENTER TO FACE	MINIMUM OUTER DIA
	C	D
6	16	15
8	22	18.5
10	24	22
15	32	27
20	35	32.5
25	43	39.5
32	51	49
40	52	56
50	64	68
65	76	84
80	89	98

ALL DIMENSIONS IN MM



Reducing Tee

FORGED 1000 Lbs BLACK

Art No. VS-1006 ▼

THE NO.1 FORGED STEEL PIPE FITTINGS



Our 'VS' fittings proved their operational superiority on fuel gas systems and are number one. These tees are made to perfection.

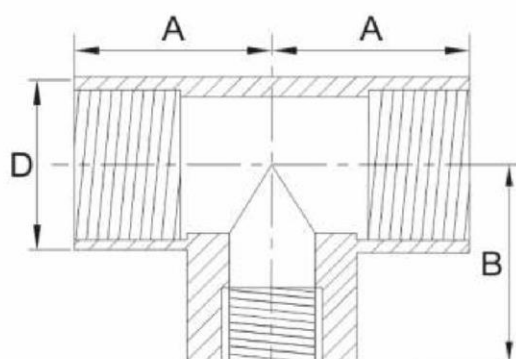

a structure for Application - Fuel Gas Transmission

DIMENSIONS AS PER IS : 1239 (Part 2) 2011 / BS EN 10241 - 2000

NOMINAL SIZE OF OUTLET	MIN. LENGTH OF CENTER TO FACE A	MIN. LENGTH OF CENTER TO FACE B	MINIMUM OUTER DIA D	NOMINAL SIZE OF OUTLET	MIN. LENGTH OF CENTER TO FACE A	MIN. LENGTH OF CENTER TO FACE B	MINIMUM OUTER DIA D
8x6	21	22	18.5	40x20	41	52	56
10x6	21	24	22	40x25	48	52	56
10x8	22	24	22	40x32	49	52	56
15x8	25	32	27	50x15	41	64	68
15x10	27	32	27	50x20	44	64	68
20x8	27	35	32.5	50x25	48	64	68
20x10	29	35	32.5	50x32	52	64	68
20x15	32	35	32.5	50x40	56	64	68
25x10	30	43	39.5	65x40	60	76	84
25x15	35	43	39.5	65x50	67	76	84
25x20	38	43	39.5	80x25	60	89	98
32x15	38	51	49	80x32	64	89	98
32x20	41	51	49	80x40	67	89	98
32x25	44	51	49	80x50	73	89	98
40x15	38	52	56	80x65	79	89	98

ALL DIMENSIONS IN MM



Cross

THE NO.1 FORGED STEEL PIPE FITTINGS

▼ Art No. VS-1007

FORGED 1000 Lbs BLACK

These 'VS' fittings are normally used in hot fluids and steam applications. Our fittings need to be equally perfect from all ends.



a structure for Application - Sugar Mills

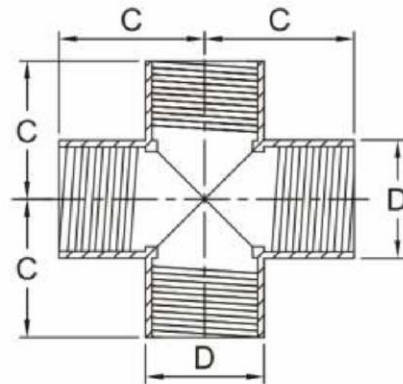

DIMENSIONS AS PER IS : 1239 (Part 2) 2011 / BS EN 10241 - 2000

NOMINAL SIZE OF OUTLET	MINIMUM LENGTH CENTER TO FACE	MINIMUM OUTER DIA
	C	D
6	16	15
8	22	18.5
10	24	22
15	32	27
20	35	32.5
25	43	39.5
32	51	49
40	52	56
50	64	68
65	76	84
80	89	98

ALL DIMENSIONS IN MM



Union

FORGED 1000 Lbs BLACK

Art No. VS-1008 ▼

THE NO.1 FORGED STEEL PIPE FITTINGS



Perfect threading and connection are what our 'VS' fittings are known for. Our forged steel fittings are much sought after in railways due to their ruggedness and reliable service life.

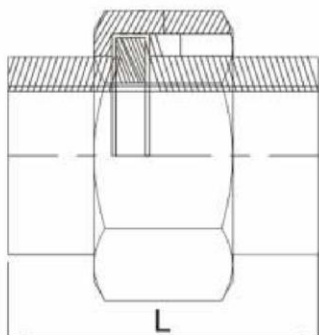

a structure for Application - Railways

DIMENSIONS AS PER IS : 1239 (Part 2) 2011 / BS EN 10241 - 2000

NOMINAL SIZE OF OUTLET	MINIMUM LENGTH
	L
6	38
8	44
10	51
15	57
20	67
25	76
32	85
40	100
50	110
65	120
80	135

ALL DIMENSIONS IN MM



Socket / Coupling

THE NO.1 FORGED STEEL PIPE FITTINGS

▼ Art No. VS-1009

FORGED 1000 Lbs BLACK

Our 'VS' fittings true to their name are very reliable in any pipe line network which is very essential in harbours.



a structure for Application - Harbours

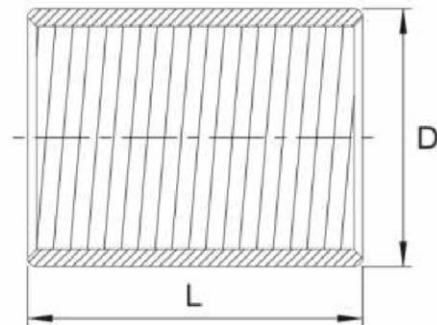

DIMENSIONS AS PER IS : 1239 (Part 2) 2011 / BS EN 10241 - 2000

NOMINAL SIZE OF OUTLET	MINIMUM LENGTH L	MINIMUM OUTER DIA D
6	19	15
8	27	18.5
10	28	22
15	37	27
20	39	32.5
25	46	39.5
32	51	49
40	51	56
50	60	68
65	69	84

ALL DIMENSIONS IN MM



Reducing Socket / Coupling

FORGED 1000 Lbs BLACK

Art No. VS-1010 ▼

THE NO.1 FORGED STEEL PIPE FITTINGS



Manufacturing these 'VS' Reducing Sockets, is a work of art which we have perfected from all angles.

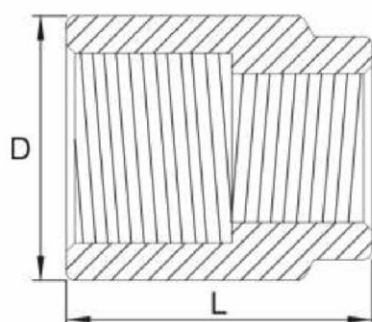

a structure for Application - ONGC

DIMENSIONS AS PER IS : 1239 (Part 2) 2011 / BS EN 10241 - 2000

NOMINAL SIZE OF OUTLET	MINIMUM LENGTH	MINIMUM OUTER DIA	NOMINAL SIZE OF OUTLET	MINIMUM LENGTH	MINIMUM OUTER DIA
	L	D		L	D
8x6	25	18.5	32x20	57	49
10x6	30	22.0	32x25	56	49
10x8	29	22.0	40x15	65	56
15x6	41	27	40x20	64	56
15x8	40	27	40x25	62	56
15x10	38	27	40x32	60	56
20x8	44	32.5	50x15	70	68
20x10	43	32.5	50x20	68	68
20x15	41	39.5	50x25	67	68
25x8	54	39.5	50x32	65	68
25x10	52	39.5	50x40	64	68
25x15	51	32.5	65x25	76	84
25x20	49	32.5	65x32	75	84
32x10	60	49	65x40	73	84
32x15	59	49	65x50	71	84

ALL DIMENSIONS IN MM



Hex. Nipple

THE NO.1 FORGED STEEL PIPE FITTINGS

▼ Art No. VS-1011

FORGED 1000 Lbs BLACK

Our 'VS' fittings have been most successfully used on pneumatic lines. Manufacturing Hex. Nipples means perfecting both the ends.



a structure for Application - Pneumatics

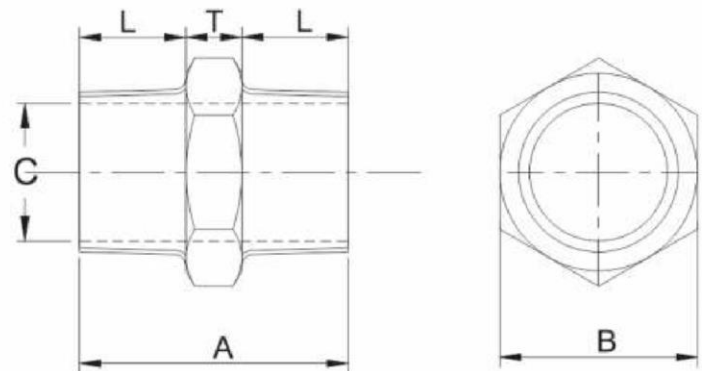

DIMENSIONS AS PER IS : 1239 (Part 2) 2011 / BS EN 10241 - 2000

NOMINAL BORE	MIN.LENGTH OF THREAD FOR BASIS GAUGE LENGTH PLUS DIA CLEARANCE L	THICKNESS OF HEXAGON T	MINIMUM OVERALL LENGTH A	MINIMUM DIAMETER OF BORE C	WIDTH ACROSS FLATS OF HEXAGON B
6	9.5	6	25	5.5	13.1
8	12.5	6	31	6.5	15.5
10	12.5	8	33	9.5	17.9
15	17.5	8	43	12.5	23.0
20	19	10	48	19	27.8
25	21	10	52	25	35.3
32	24	11	59	32	47.2
40	24	13	61	38	52.0
50	27	14	68	51	61.1
65	32	16	80	64	79.0
80	35	19	89	76	92.0

ALL DIMENSIONS IN MM



Reducing Hex. Nipple

FORGED 1000 Lbs BLACK

Art No. VS-1012 ▼

THE NO.1 FORGED STEEL PIPE FITTINGS



When ever the word automobiles is used, it personifies strength & our 'VS' fittings mean strength in every way.

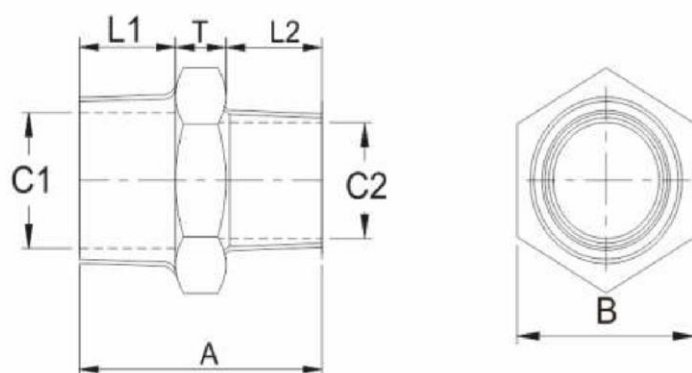

a structure for Application - Automobile Industry

DIMENSIONS "VS" REDUCING HEX. NIPPLE

NOMINAL BORE	MIN.LENGTH OF THREAD FOR BASIS GAUGE LENGTH PLUS DIA CLEARANCE		THICKNESS OF HEXAGON T	MINIMUM OVERALL LENGTH A	MINIMUM DIAMETER OF BORE		WIDTH ACROSS FLATS OF HEXAGON B
	L1	L2			C1	C2	
8x6	12.5	9.5	6	28	6.5	5.5	15.5
10x8	12.5	12.5	8	33	9.5	6.5	17.9
15x8	17.5	12.5	8	38	12.5	6.5	23.0
15x10	17.5	12.5	8	38	12.5	9.5	23.0
20x10	19	12.5	10	41.5	19	9.5	27.8
20x15	19	17.5	10	46.5	19	12.5	27.8
25x15	21	17.5	10	48.5	25	12.5	35.3
25x20	21	19	10	50	25	19	35.3
32x20	24	19	11	54	32	19	47.2
32x25	24	21	11	56	32	25	47.2
40x25	24	21	13	58	38	25	52.0
40x32	24	24	13	61	38	32	52.0
50x32	27	24	14	65	51	32	61.1
50x40	27	24	14	65	51	38	61.1

ALL DIMENSIONS IN MM



Plug

THE NO.1 FORGED STEEL PIPE FITTINGS

▼ Art No. VS-1013

FORGED 1000 Lbs BLACK

'VS' fittings are being used in textile Industries also. Our plug is a versatile component on almost every type of pipeline for plugging of fluid flow.



a structure for Application - Textiles

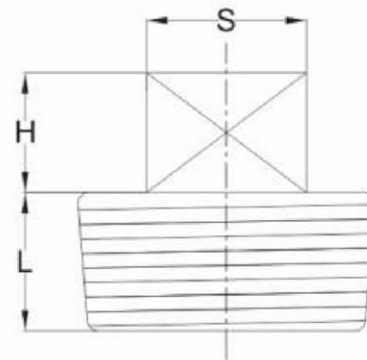

DIMENSIONS AS PER IS : 1239 (Part 2) 2011 / BS EN 10241 - 2000

NOMINAL SIZE	MIN. LENGTH OF THREAD FOR BASIC GAUGE	APPROX. SIZE OF SQUARE	APPROX. HEIGHT OF SQUARE
	L	S	H
6	6.5	6	6
8	9.7	9	6
10	10.1	11	10
15	13.2	13	10
20	14.5	14	12
25	16.8	17	12
32	19.1	22	16
40	19.1	27	16
50	23.4	32	19
65	26.7	37	19
80	29.8	37	22

ALL DIMENSIONS IN MM



Hex. Bush

FORGED 1000 Lbs BLACK

Art No. VS-1014 ▼

THE NO.1 FORGED STEEL PIPE FITTINGS



Manufacturing these 'VS' fittings for fire fighting applications require a lot of consistency and skill and certainly our product meets those standards.

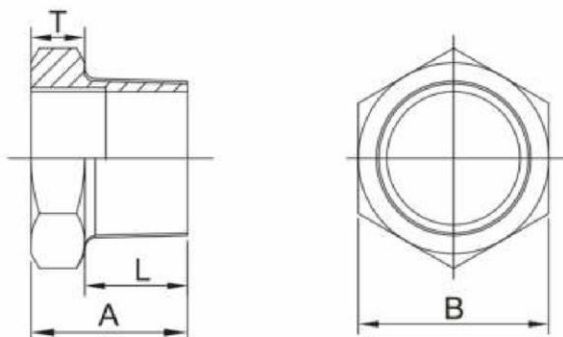

a structure for Application - Fire Fighting

DIMENSIONS AS PER IS : 1239 (Part 2) 2011 / BS EN 10241 - 2000

NOMINAL SIZE MM	MIN.LENGTH OF USEFUL THREADS FOR BASIC GAUGE LENGTHS PLUS CLEARANCE L	THICKNESS OF HEXAGON MAX. T	OVERALL LENGTH MIN. A	WIDTH ACROSS FLATS OF HEXAGON B
8x6	12.5	6	18.5	15.5
10x8	12.5	7	20.5	17.9
15x8	17.5	8	25.5	23.0
15x10	17.5	7	25.5	23.0
20x10	19	10	29	27.8
20x15	19	10	29	27.8
25x15	21	10	31	35.3
25x20	21	10	31	35.3
32x15	24	11	35	47.2
32x20	24	11	35	47.2
32x25	24	11	35	47.2
40x20	24	13	37	52.0
40x25	24	13	37	52.0
40x32	24	13	37	52.0
50x25	27	14	41	61.1
50x32	27	14	41	61.1
50x40	27	14	41	61.1



THE NO.1
FORGED STEEL
PIPE FITTINGS

NISHA SALES

OFFICE: 1045, RAVIVAR PETH, SHOP NO. 5, VISHWASHANTI APTS., PUNE, MAHARASHTRA.
MOBILE: +91-9325295707 / +91-9325299077 | LANDLINE: 020-24458444 | EMAIL: nishasales@gmail.com